



Embedded Solutions

Universal Modules

General Description

Following figure shows the general block diagram of Universal module:

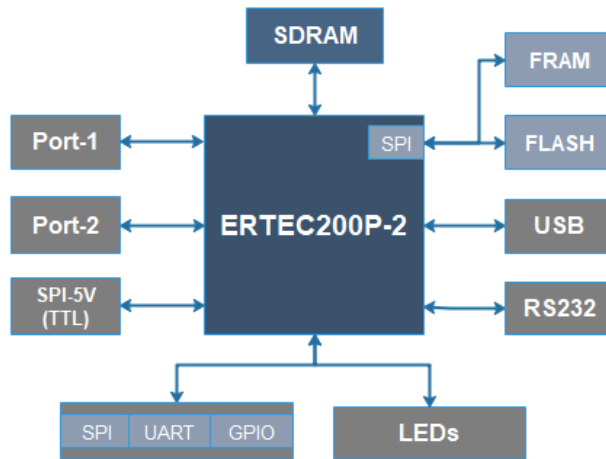
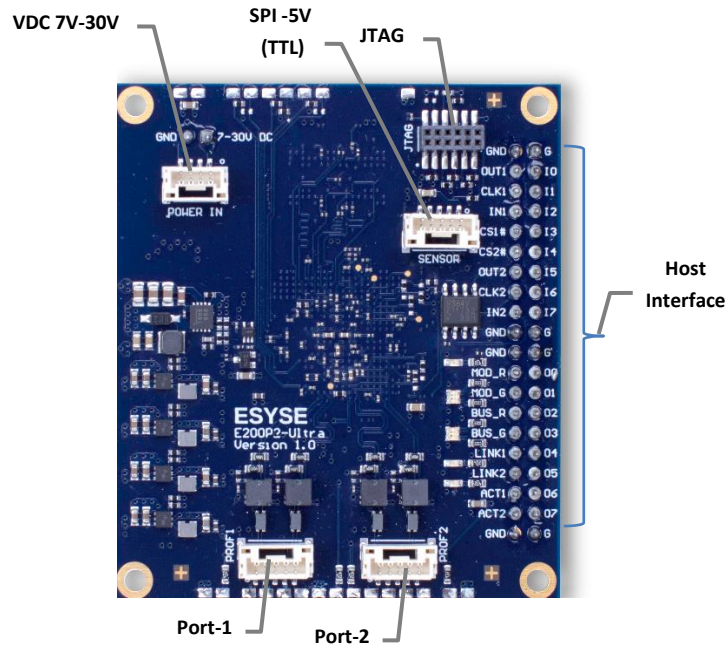

Figure 1: General Block diagram ESYSE-E200P2-XXXX





Following table shows the general description of ESYSE-E200P2-XXXX communication modules:

General Description	
Temperature area:	-45° - 85°
Power-Supply:	7V- 30V DC Input,
Power consumption:	Wattage: min. 0.5VA, max. 3VA, Nominal: 1VA (with 1 millisecond network connection IO-cycle time)
SDRAM:	64 MB
ROM	8/16/32 MB
FRAM:	8/16 KB
Ethernet Connection:	<ul style="list-style-type: none"> - RJ45 Connector - M12, JST, Borad-to-Board / Wire-to-Board
Host Interface:	<ul style="list-style-type: none"> - SPI / UART (3.3 V) or - SPI-TTL (5 V)
Status LEDs:	Module and Net Bicolor, Link-LEDs (Port-1 and Port-2)
GPIO:	Additional configurable Digital Input/Output
Programming Interface:	JTAG -Interface for ARM Debugger
RS232	Serial D-SUB 9-Pin
USB:	Micro-USB Connector
Fieldbus Protocols:	<p>PROFINET:</p> <ul style="list-style-type: none"> - PROFINET Version 2.33, - Performance Class CCA,CCB and CCC (MRP, RT and IRT) - Media Redundancy: MRP, MRPD, - System Redundancy, - min. IO-Cycle Time: 125 microsecond, - Shared Device, - Fast-Startup, - Motion Control (Optional): <ul style="list-style-type: none"> o PROFIdrive Version V4.2 Axis-Control: Speed and Positioning o PROFIdrive Version V4.2 Encoder Device Profile. - PROFIsafe: as Black-Box communication module, <p>EtherNet/IP:</p> <ul style="list-style-type: none"> - Dual Port integrated switch, - ACD (Address Collision Detection), - DLR (Device Level Ring), - Max. simoultaneously Implecit Messaging (IO-Connections): 5, - Max. Explicit Messageing: 15, - Min. IO-connection cycle time: 1ms, - CIP-Safety: as Black-Box communication module, <p>PROFIBUS: DPV0, DPV1 and DPV2</p> <ul style="list-style-type: none"> - EtherCAT, - MODBUS,
Additional standard protocols:	Webserver, OPC-UA, MQTT, IP-Telemetry
Applications: (Available by ESYSE)	<ul style="list-style-type: none"> - Drive: Servo Drive Motion Control Systems (Positioning and speed control) - Encoder: SSI, BiSS-B, BiSS-C, Endat,... - Pump, - Valve, - IO-Device, - Gateway, - General Communication module - User specific (Programmable via JTAG-Interface)

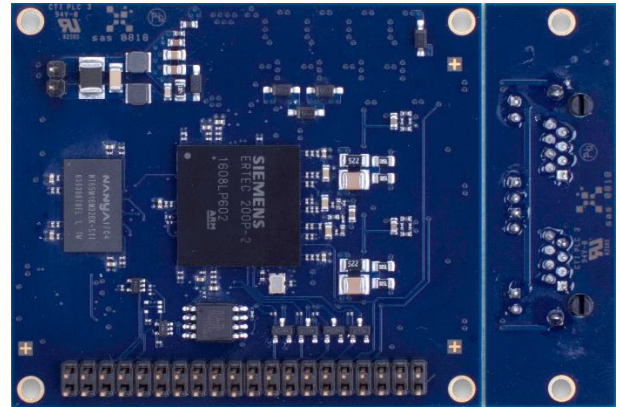
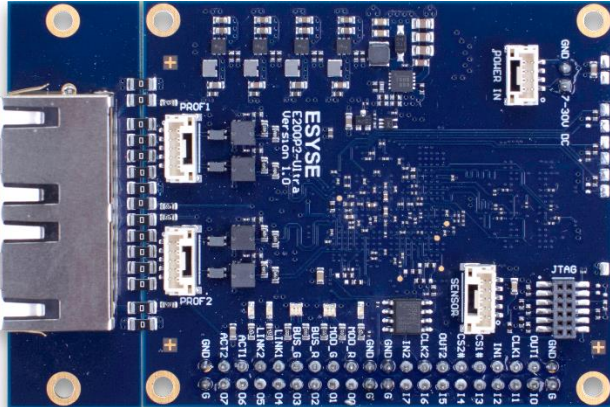

Description	General Description	Refer to table above
	Order-ID:	ESYSE-E200P2-LAN
	Dimension:	85mm x 58mm
	Ethernet Connection:	RJ45